



Table Of Contents

Motor Selection Guide	2 - 12
- Shades, Shutters and Doors - Retractable Awnings	
Installation Instructions	13 - 19
- Operator Adaptors - Operator Limit Adjustment - Wiring Considerations - Hz Operator Quick Programming Guide	
Operators	20 - 32
- Type 3.5, Type 5, Type 6, Type 5DMI, Type 6DMI, Type 5 Hz, Type 5 DMI Hz, Type 6 Hz and Type 6 DMI Hz (Uses: Shade, Shutter and Awnings)	
- Type 8, Type 9 and Type Central (Uses: Shutters, Doors)	
Operator Accessories	33 - 42
- Safety Brakes, Motor Brackets and Adaptors	
Electronic Controls	43 - 57
- Hz Wireless Controls, Radio Controls, Environmental Controls, Battery Back Control, Switches and Transformers	
Manual Accessories	58 - 70
- Gears, Universals, Springs, Handles, Wall Brackets and Plates	



Motor Selection Guide For Rolling Shutters and Doors

To select a motor in this guide you need to know the following:

1. Type of Slat: Height and Width
2. Total weight of shutter
3. Diameter of the tube

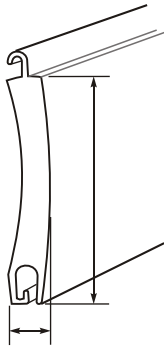

Type of slat:

It is important to consider the total size of the product you plan to produce before choosing an operator, since these variables affect the weight of what an operator can lift. The following charts represent some of the most common motor solutions. Choose the one that most closely corresponds to the weight that you calculate.

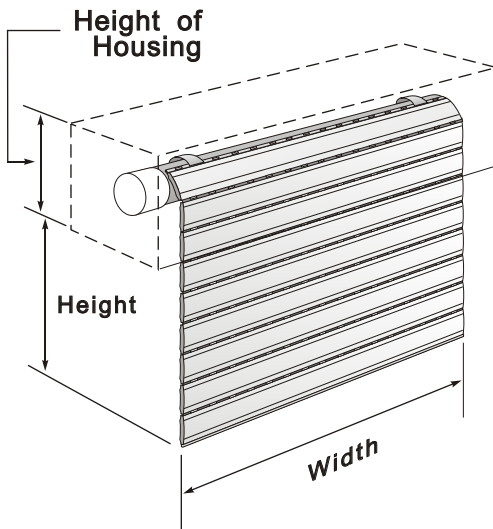

Total Weight of Shutter

$$\text{Total weight} = \text{Width} \times \underbrace{(\text{Height} + \text{Height of Housing})}_{\text{surface}} \times \text{Weight per sq. ft.}$$

Important Note:

The choice of a motor also depends on the type of installation.

- If you use one motor for two or more shutters add 20% for the first additional shutter to derive the total weight. Add an additional 10% for every shutter after that.

Examples: 2 shutters/one motor = + 20% to the total weight.

3 shutters/one motor = + 20% + 10% to the total weight.

- If the shutter is over 9 feet in height, add 10% to the total weight for every three feet beyond.

Example: 11 feet in height= total weight + an additional 10% to the effective load to be lifted.

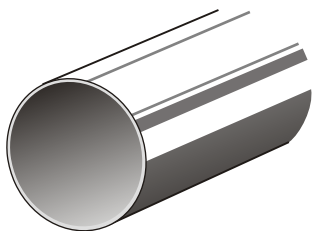

Diameter of Tube:

The lifting capacity of an operator decreases when the tube diameter increases. Therefore, it is necessary to choose the smallest tube while considering the load capacity of the tube and the optimum roll-up diameter of the slats. Keep in mind that if tube spacer rings are used, you have increased the tube diameter.

After choosing the chart that corresponds to the tube size being used, select the operator according to the total weight of the shutter.



Motor Selection Guide For Type 3.5 Operators

36mm (1.5 inch) TUBE DIAMETER

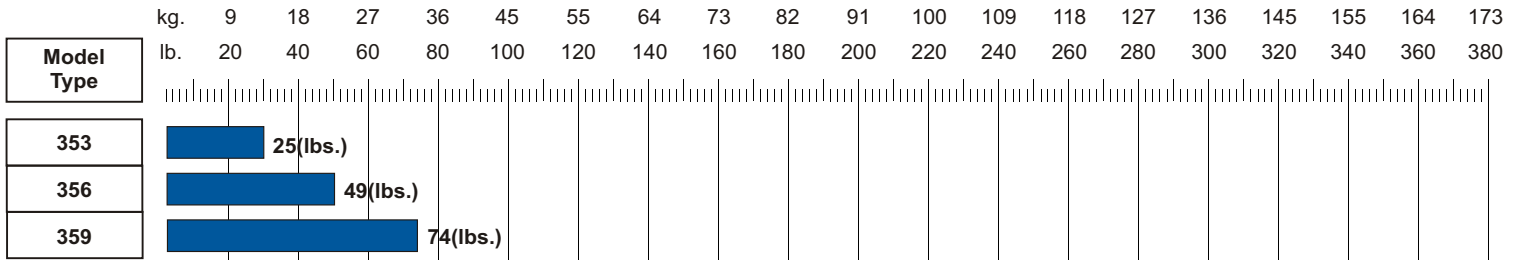

40mm (1.7 inch) TUBE DIAMETER

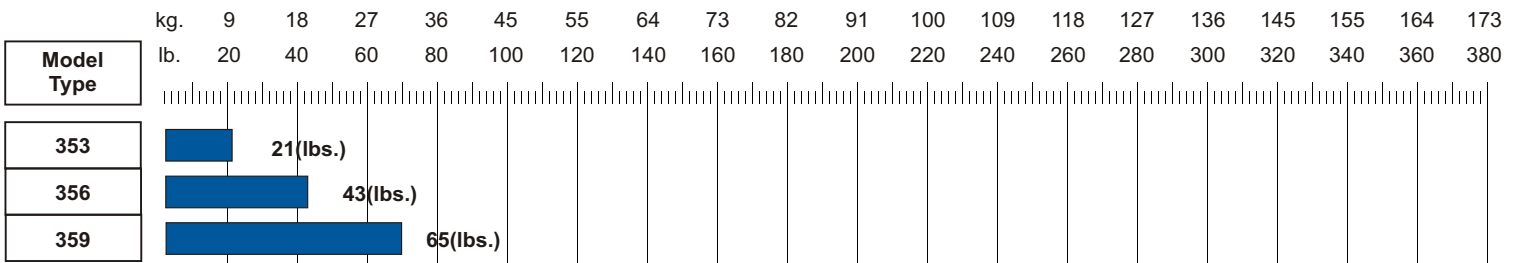

50mm (2.0 inch) TUBE DIAMETER

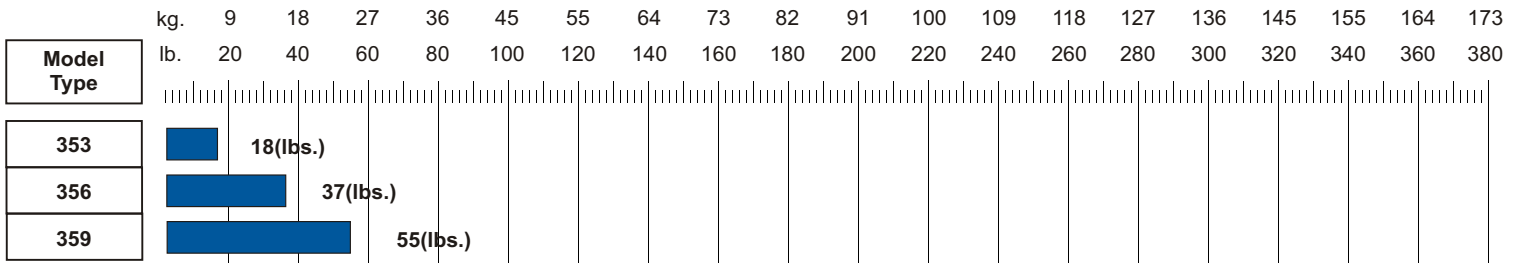

-This chart reflects the recommended 30% security factor that is used for most applications.

-Shutters more than 9 feet high: add 10% to the effective load for every additional 3 feet.

-Double span shutters: add 20% to the effective load to be lifted.

-All chart calculations are based on the (O.D.) outside diameter. Please take caution when sizing shutters with tube spacer rings as this will reduce the amount of operator lifting capacity.



Motor Selection Guide For Type 5 Operators

85mm (3.25 inch) TUBE DIAMETER

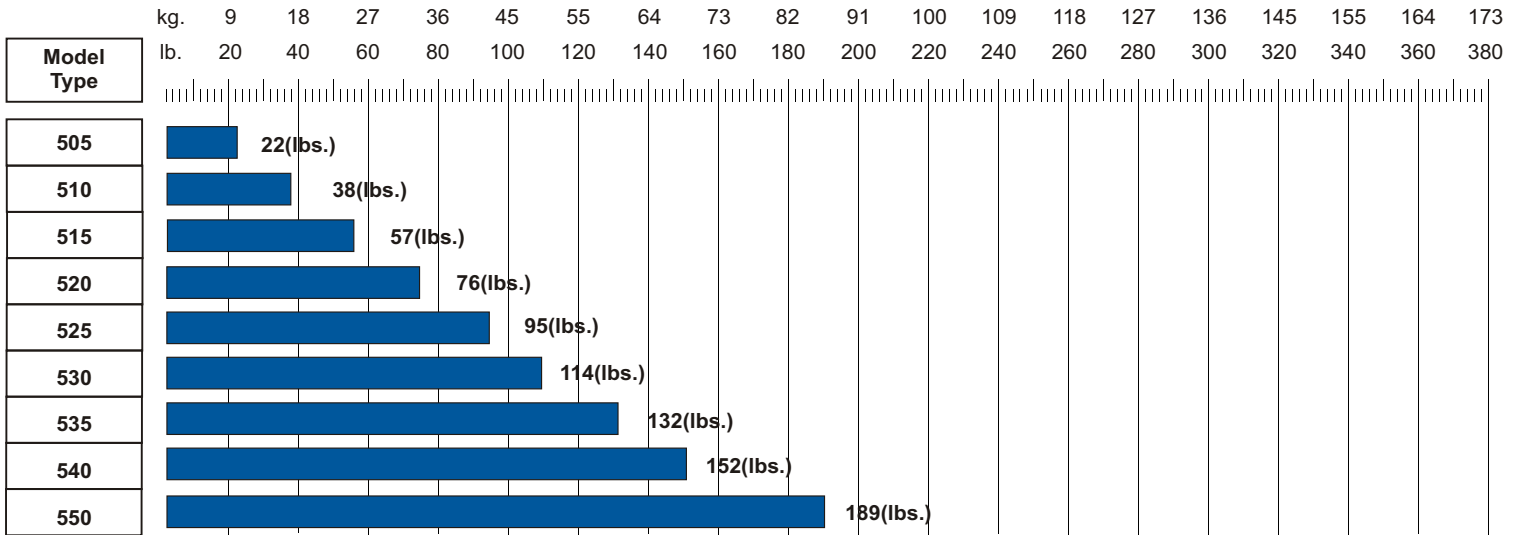

90mm (3.5 inch) TUBE DIAMETER

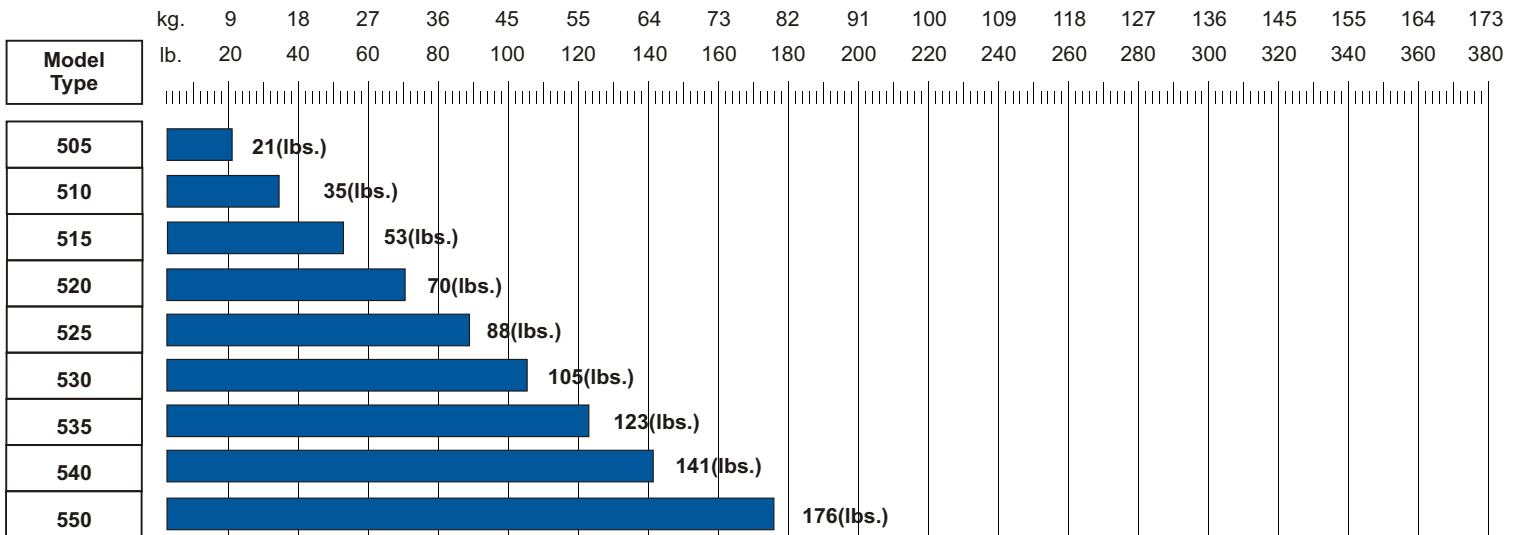

-This chart reflects the recommended 30% security factor that is used for most applications.

-Shutters more than 9 feet high: add 10% to the effective load for every additional 3 feet.

-Double span shutters: add 20% to the effective load to be lifted.

-All chart calculations are based on the (O.D.) outside diameter. Please take caution when sizing shutters with tube spacer rings as this will reduce the amount of operator lifting capacity.



Motor Selection Guide For Type 6 Operators

60mm (2.5 inch) TUBE DIAMETER

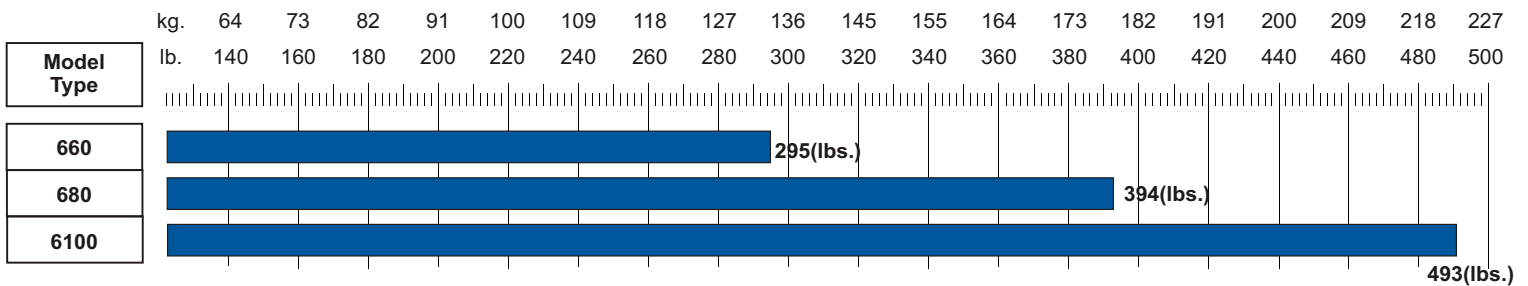

70mm (2.75 inch) TUBE DIAMETER

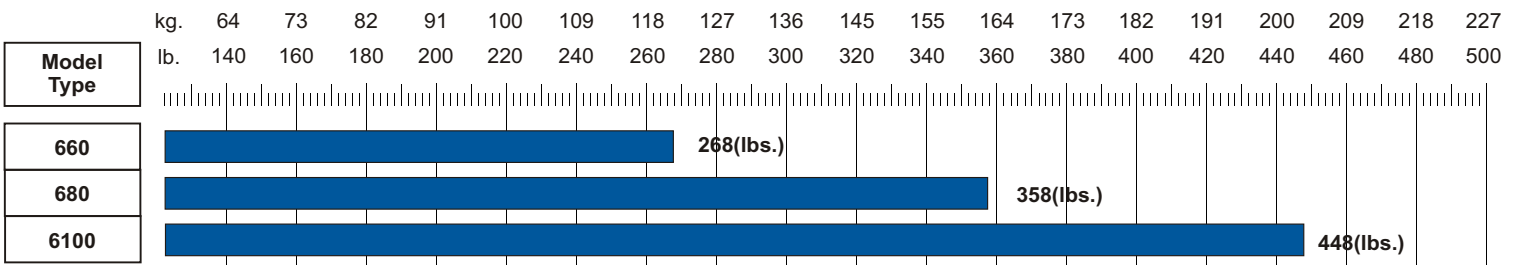

78mm (3.0 inch) TUBE DIAMETER

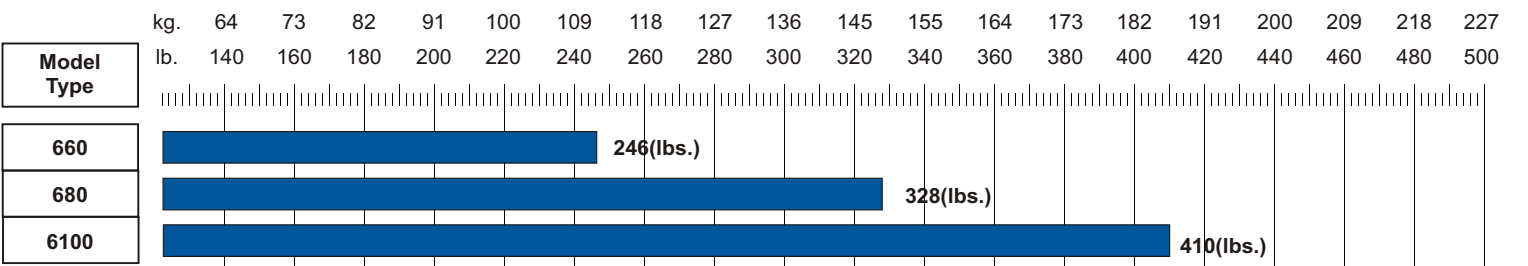

-This chart reflects the recommended 30% security factor that is used for most applications.

-Shutters more than 9 feet high: add 10% to the effective load for every additional 3 feet.

-Double span shutters: add 20% to the effective load to be lifted.

-All chart calculations are based on the (O.D.) outside diameter. Please take caution when sizing shutters with tube spacer rings as this will reduce the amount of operator lifting capacity.



Motor Selection Guide For Type 6 Operators

85mm (3.25 inch) TUBE DIAMETER

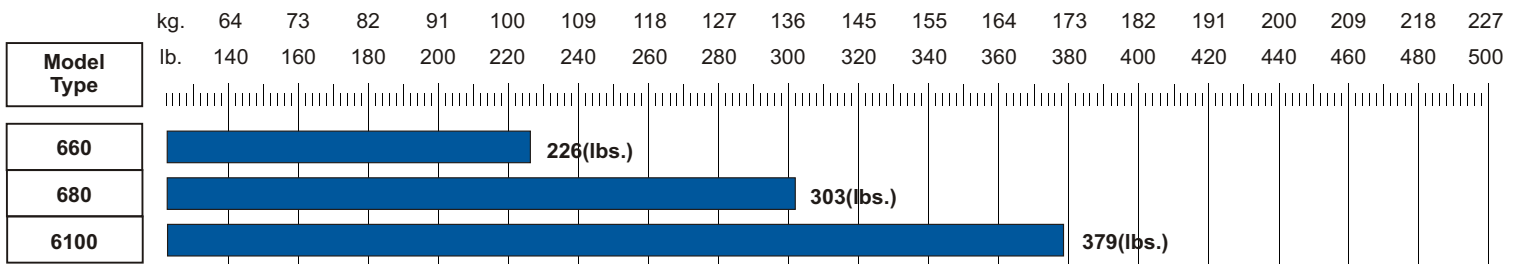

90mm (3.5 inch) TUBE DIAMETER

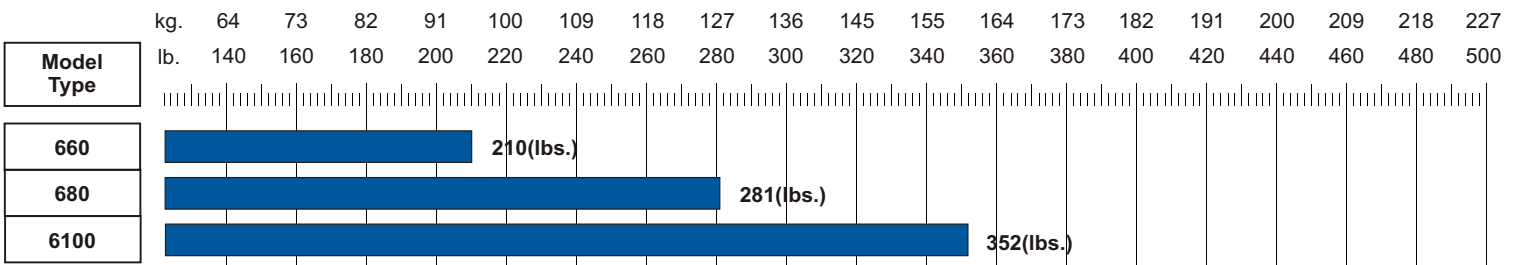

100mm (4.0 inch) TUBE DIAMETER

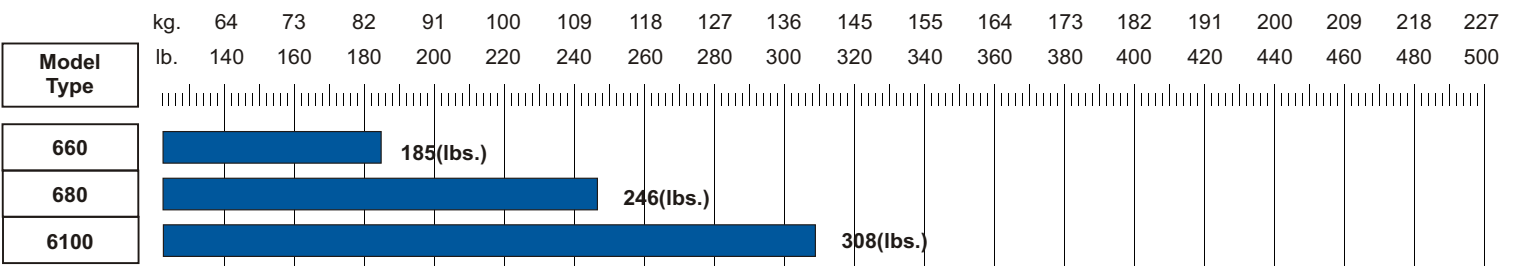

-This chart reflects the recommended 30% security factor that is used for most applications.

-Shutters more than 9 feet high: add 10% to the effective load for every additional 3 feet.

-Double span shutters: add 20% to the effective load to be lifted.

-All chart calculations are based on the (O.D.) outside diameter. Please take caution when sizing shutters with tube spacer rings as this will reduce the amount of operator lifting capacity.



Motor Selection Guide For Type 8 Operators

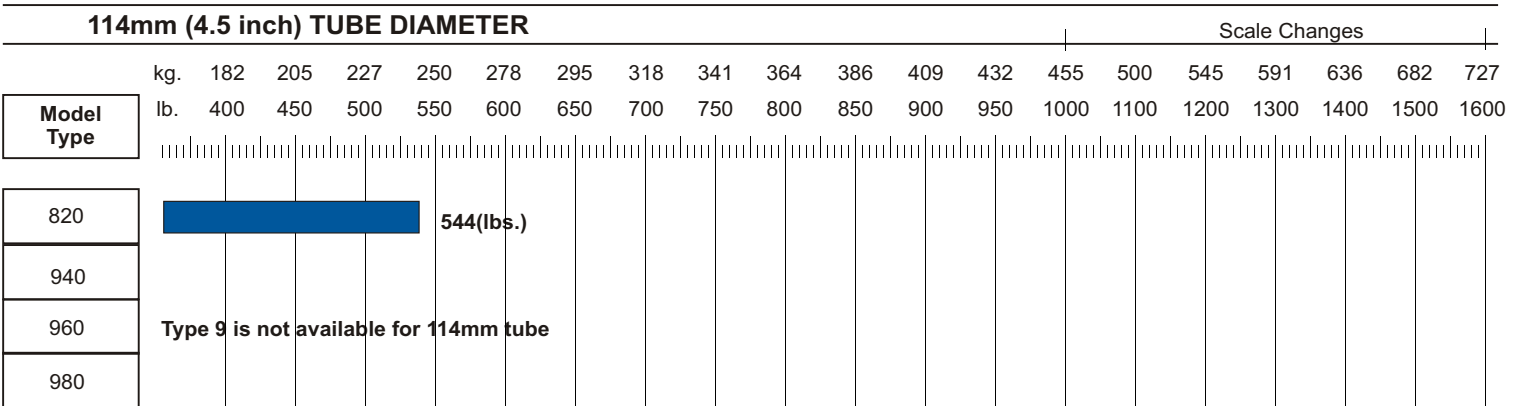
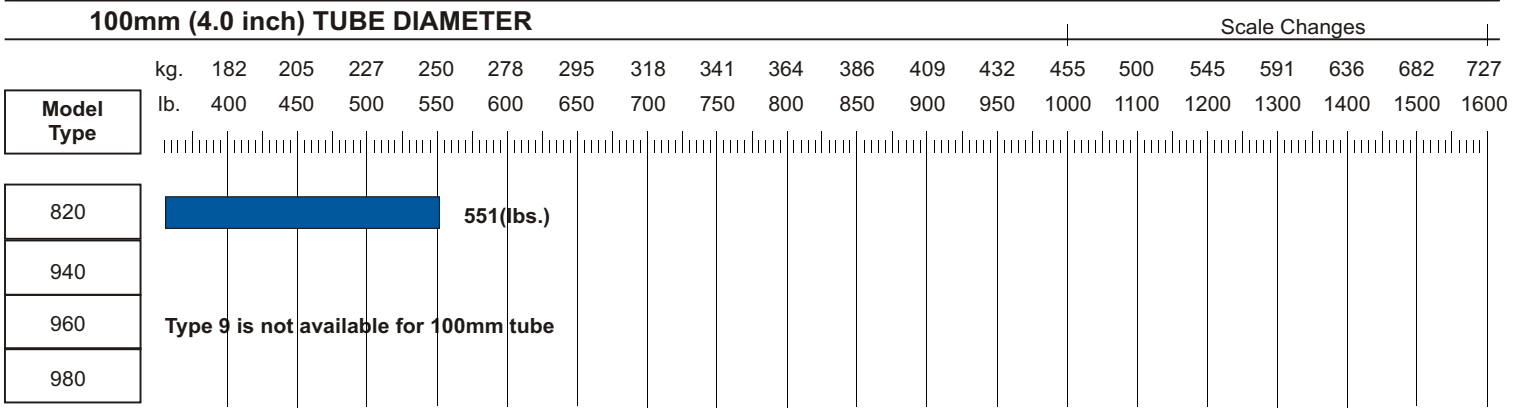

-This chart reflects the recommended 30% security factor that is used for most applications.

-Shutters more than 9 feet high: add 10% to the effective load for every additional 3 feet.

-Double span shutters: add 20% to the effective load to be lifted.

-All chart calculations are based on the (O.D.) outside diameter. Please take caution when sizing shutters with tube spacer rings as this will reduce the amount of operator lifting capacity.



Motor Selection Guide

For Type 8 and Type 9 Operators

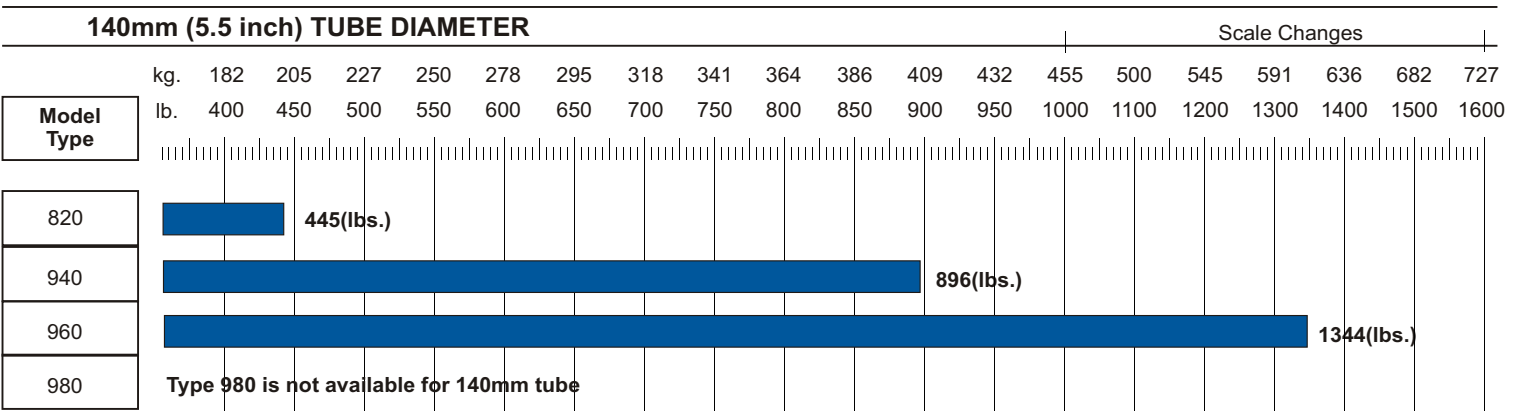
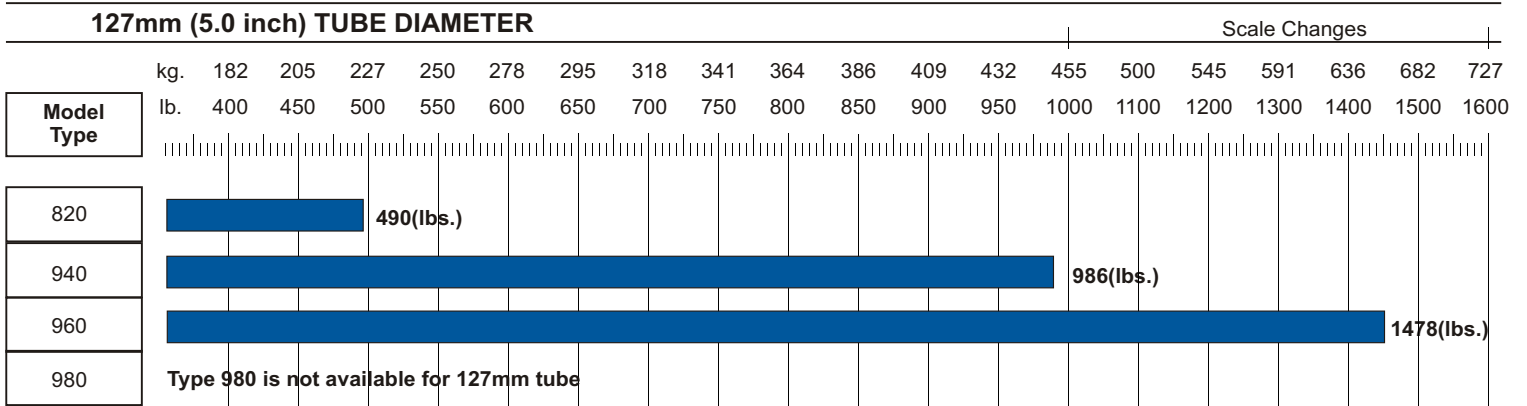

-This chart reflects the recommended 30% security factor that is used for most applications.

-Shutters more than 9 feet high: add 10% to the effective load for every additional 3 feet.

-Double span shutters: add 20% to the effective load to be lifted.

-All chart calculations are based on the (O.D.) outside diameter. Please take caution when sizing shutters with tube spacer rings as this will reduce the amount of operator lifting capacity.



Motor Selection Guide

For Type 8 and Type 9 Operators

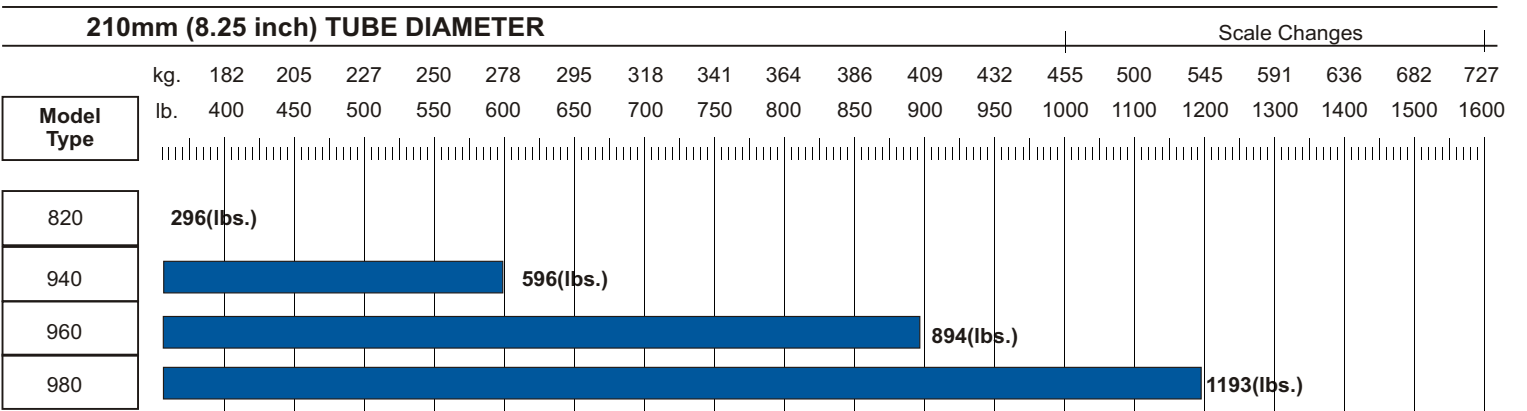
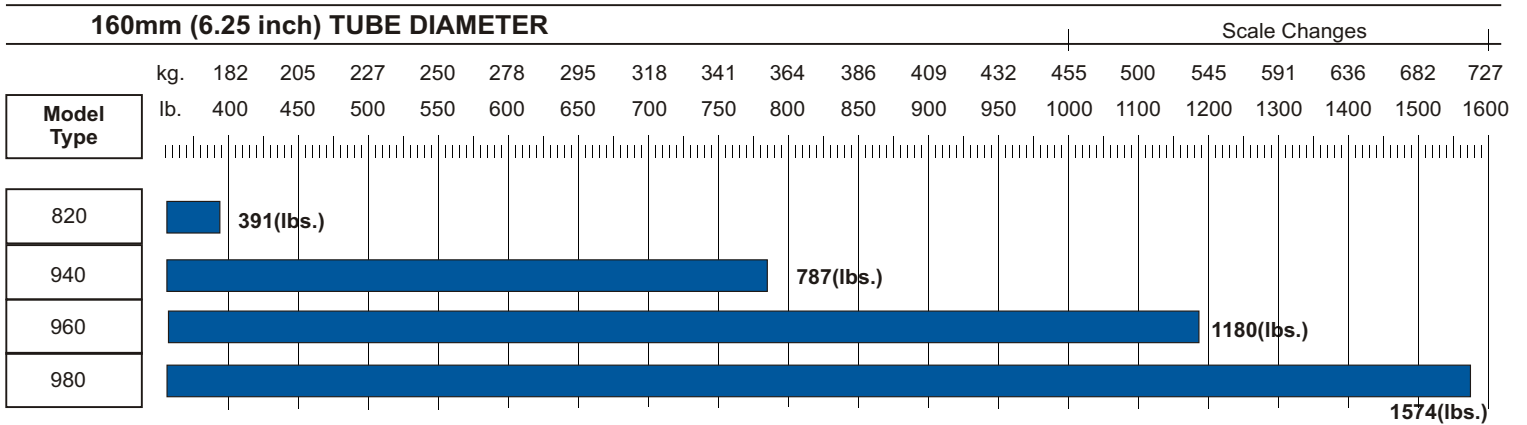

-This chart reflects the recommended 30% security factor that is used for most applications.

-Shutters more than 9 feet high: add 10% to the effective load for every additional 3 feet.

-Double span shutters: add 20% to the effective load to be lifted.

-All chart calculations are based on the (O.D.) outside diameter. Please take caution when sizing shutters with tube spacer rings as this will reduce the amount of operator lifting capacity.



Motor Selection Guide For Retractable Awning Systems

		1 Pair (2 arms)	2 Pair (4 arms)	3 Pair (6 arms)	4 Pair (8 arms)	5 Pair (10 arms)	6 Pair (12 arms)
		20 ft. (6m)	33 ft. (10m)	50 ft. (15m)	66 ft. (20m)	82 ft. (25m)	100 ft. (30m)
A	D						
Projection of Arms	Roller Tube O.D. Sizes						
5 ft. (1.50m)	2.5" (63)	525		535	550	660	
	3.0" (78)	535		550	660	680	
	3.5" (89)	535	550	660	680		
6.5 ft. (2.00m)	2.5" (63)	525	535	540	660	680	6100
	3.0" (78)	535	540	550	660	680	
	3.5" (89)	540	550	660	680		
8 ft. (2.40m)	2.5" (63)	535	550		660	6100	
	3.0" (78)	550		660	680		
	3.5" (89)	550	660	680			
9 ft. (2.70m)	2.5" (63)	540	550	660	680		
	3.0" (78)	550	660	680	6100		
	3.5" (89)	550	660	680	6100		
10 ft. (3.00m)	2.5" (63)	540	550	680			
	3.0" (78)	550	680			6100	
	3.5" (89)	660	680	6100			
13.5 ft. (4.00m)	2.5" (63)	550	680	6100			
	3.0" (78)	680	6100				
16.5 ft. (5.00m)	2.5" (63)	550	680				
	3.0" (78)	680	6100				

Above chart is approximate.
For more specific information, refer to factory.

This chart can be used to select the most suitable type of motor for your lateral arm awning system.

Important: The lateral arms referred to here are the standard aluminum type with built-in tension springs. When considering arms made of steel and/or using other types of spring mechanisms, please request additional information.

1. Locate the projection of your lateral arm on the above chart at point (A); e.g. 5 ft., 6 ft., 8 ft., etc.
2. Determine which roller tube diameter (D) is being used in your installation.

3. Locate the number of arms (B) and the length of your installation (C).
4. Read the correct motor from the chart at the intersection of your selections.

NOTE:

Because this chart must take into consideration lateral arms being manufactured by many different companies, it is only approximate. The relationship between the number of arms and the length of the awning is only a guide and will vary slightly from manufacturer to manufacturer.



Adaptor Installation Instructions

Installation Instructions For Snap-On Adaptors

Type 3.5 / Type 5 / Type 6 / Type 5DMI / Type 6DMI

HARD CLIP (Fixed)

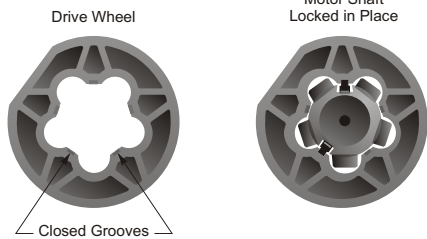

SOFT CLIP (Removable)

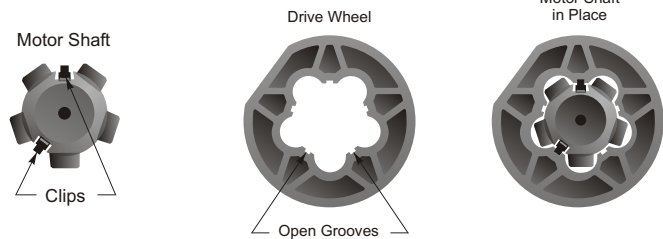

Installation of the drive wheel to the motor shaft:

Push the drive into the motor shaft until you hear a "click". Two clips lock the drive wheel into the motor shaft.

There are two types of drive wheels: Removable or "Soft Clip" type, and fixed or "Hard Clip" type.

The "Soft Clip" drives are available only for round tubes in 2", 2.5" and 2.75" diameters. The drive wheel can be removed by physically pulling it off the motor shaft. For the ease of identification all "Soft Clip" drives are brown.

The "Hard Clip" drives can only be removed from the shaft by pressing the two clips inward at the same time. The motor must be out of the tube in order to have access to the clips. These drives are black.

Installation in round tubes:

The drive must be riveted to the tube after the motor is inserted.

Installation in profiled tubes:

The drive doesn't need to be riveted to the tube because it is already in a positive lock position within the profiled tube.

Installation Instructions For Adaptors

Type 8 / Type 9 Operators

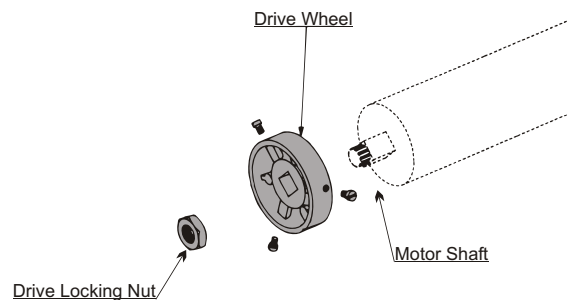



Limit Switch Adjustment

Type 3.5 / Type 5 / Type 6

Type 8 and Type 9 Operators

MATERIAL ROLLS DOWN ON SAME SIDE AS LIMITS

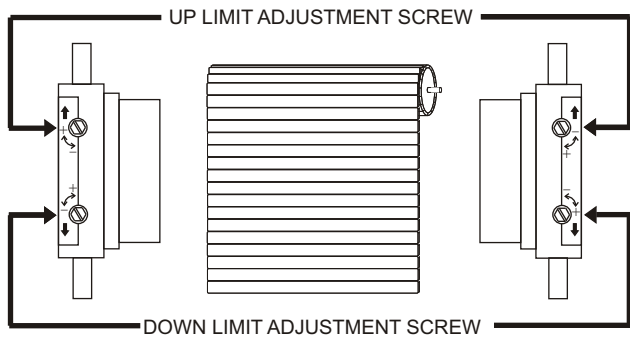

1

MATERIAL ROLLS DOWN ON OPPOSITE SIDE FROM LIMITS

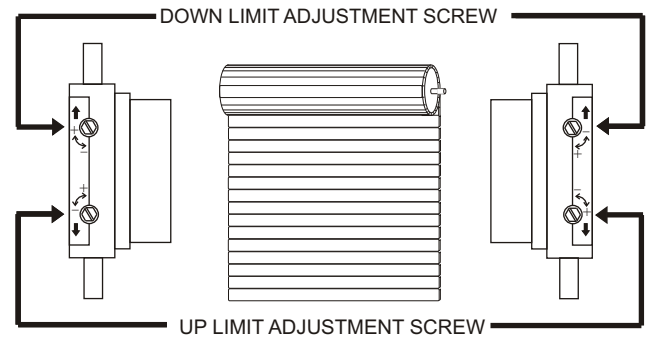

2

1) Identify which limit adjustment screw controls the up limit and which controls the down limit (see above diagrams). It is important to note that the arrows by the limit adjustment screw refer to the tube's rotation. Thus if the material comes off the tube on the back side and the limit adjustment screws face the front (as per diagram 2), the limit adjustment screw facing up controls the down limit and vice versa.

2) Turning an adjustment screw clockwise will increase the maximum travel in the direction that it controls, and turning it counterclockwise will decrease the maximum travel.

3) To set a limit, run the motor in the selected direction.

4) If the motor stops on its own before reaching the desired stop, turn the appropriate limit screw positive (clockwise). Every 2 to 3 turns of the limit adjustment screw will allow the motor to travel about 1 inch further. After every few turns of the limit adjustment screw, use the control switch to move the motor to the new limit position. (If the motor does not stop on its own before reaching the desired limit, go to step 6)

5) When you are approximately at the desired limit position, use the control switch to run the motor away from the limit 2 to 3 feet, and then back. This will allow you to see precisely where the limit is set. Make small adjustments and repeat.

6) If the motor does not stop on its own at least 6 inches before the desired limit position, stop the motor with the control switch. Then turn the limit adjustment screw in the negative (counterclockwise) direction. Confirm that the motor is stopped at the limit and set the limit as per steps 4 and 5. If the motor is not stopped at the limit, continue turning the limit adjustment screw **counterclockwise** (up to 120 turns may be required)

NOTE: The motor has a built in thermal cutoff. If after several minutes of use the motor will not run in either direction, allow the motor to cool for approximately 20 minutes.



Limit Switch Adjustment Type 5 and Type 6 DMI Operators

LIMIT ADJUSTMENT SCREWS ON OPPOSITE SIDE FROM MOTOR CABLE

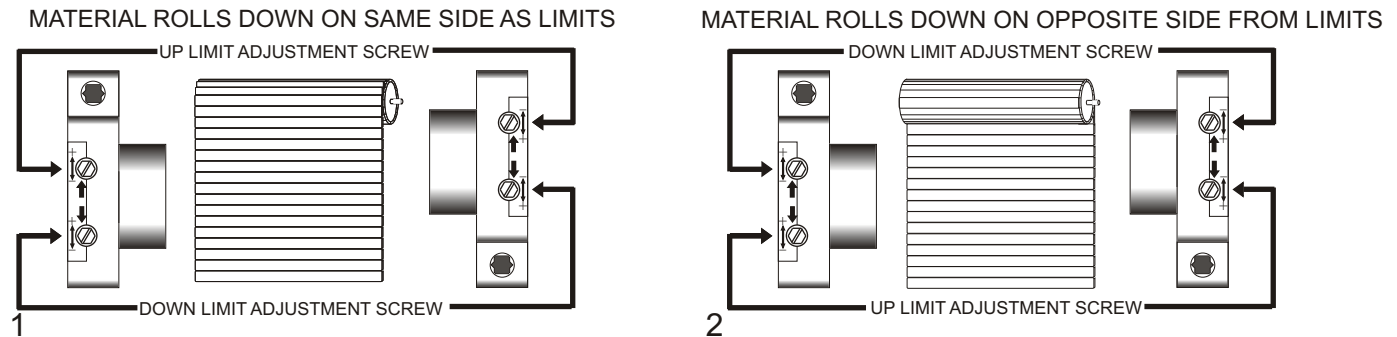

LIMIT ADJUSTMENT SCREWS ON SAME SIDE AS MOTOR CABLE

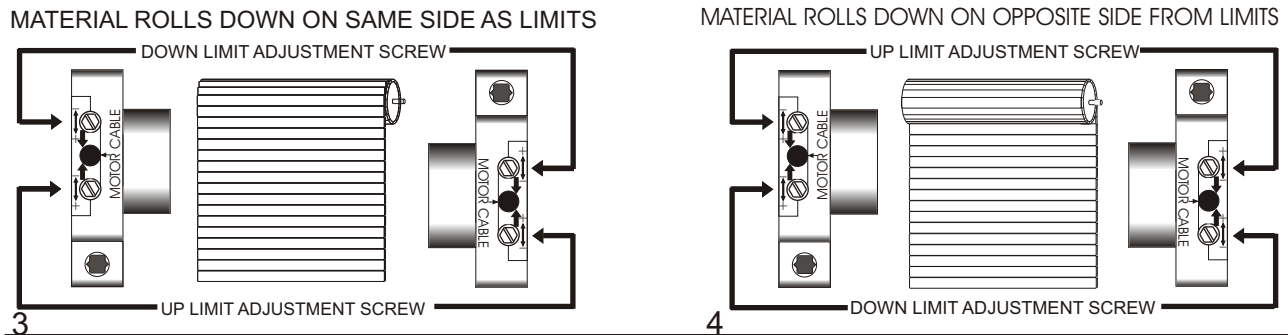

1) Identify which limit adjustment screw controls the up limit and which controls the down limit (see above diagrams). It is important to note that the arrows by the limit adjustment screw refer to the tube's rotation. Thus if the material comes off the tube on the back side and you are adjusting the limits from the side that the motor cable is not on (as per diagram 2), the limit adjustment screw with the arrow facing up controls the down limit and vice versa.

2) Turning an adjustment screw positive (+) will increase the maximum travel in the direction that it controls, and turning it negative (-) will decrease the maximum travel. **For the adjustment screws on the side without the motor cable**, turning clockwise is positive (+) and counterclockwise is negative (-). **For the adjustment screws on the side with the motor cable**, turning clockwise is negative (-) and counterclockwise is positive (+)

3) To set a limit, run the motor in the selected direction.

4) If the motor stops on its own before reaching the desired stop, turn the appropriate limit screw positive. Every 2 to 3 turns of the limit adjustment screw will allow the motor to travel about 1 inch further. After every few turns of the limit adjustment screw, use the control switch to move the motor to the new limit position. (If the motor does not stop on its own before reaching the desired limit, go to step 6)

5) When you are approximately at the desired limit position, use the control switch to run the motor away from the limit 2 to 3 feet, and then back. This will allow you to see precisely where the limit is set. Make small adjustments and repeat.

6) If the motor does not stop on its own at least 6 inches before the desired limit position, stop the motor with the control switch. Then turn the limit adjustment screw in the negative direction. Confirm that the motor is stopped at the limit and set the limit as per steps 4 and 5. If the motor is not stopped at the limit, continue turning the limit adjustment screw. (up to 120 turns may be required)

NOTE: The motor has a built in thermal cutoff. If after several minutes of use the motor will not run in either direction, allow the motor to cool for approximately 20 minutes.



Wiring Considerations

(Four Wire Operators)

Because of the type of motor (Asynchronous with built-in capacitor) and the built-in limit switches, it is important to follow two important recommendations to assure proper operation of the motorized systems - SIMU operators are not universal motors.

1. Do Not Wire SIMU Operators in Parallel. Parallel Wiring Means: Several Operators are Wired to Only One Electrical Contact Per Direction of Rotation.

There will be constant feedback from one motor to another, so stopping points will not be stable and there is a risk of motor burn out.

Correct:

Correct wiring solution is to use a double pole, double throw, center off switch which would isolate both motors.

Incorrect:

Motor A stops at its limit in direction 2 before Motor B. Current in Motor B feeds back to Motor A through the capacitor C2 and microswitches M3 and M1. Both operators keep rotating in opposite directions at reduced power.

2. Do Not Control One SIMU Operator from Several Locations Without Using a Proper Controller.

Correct:

Possible problem: When switch (1) is turned on, the motor will begin running in direction 1. As it reaches its limit, the microswitch M1 will open. If at the same moment in time switch (2) is turned on, the motor will operate in the opposite direction. This is why we recommend the use of momentary switches with the SIMU TR115 sequence relay control.

Incorrect:

The microswitch M1 closes, short-circuiting the capacitor which is loaded at its maximum voltage (180V). As a result the microswitch M1 is damaged. Solution: Use relays to build priorities between controls sending opposite signals. Do not use standard a "light" switch as a motor control.

Note: SIMU Control Systems are designed to comply with these two basic criteria and assure reliable operation of motorized systems. Non-compliance to these two basic principles void the SIMU warranty.

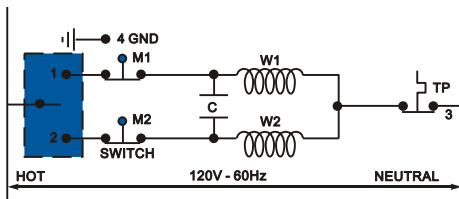

CORRECT

SYMBOLS			
M1	Microswitch	W2	Motor Winding
M2	Microswitch	TP	Thermal Protector
C	Capacitor	GND	Ground
W1	Motor Winding		

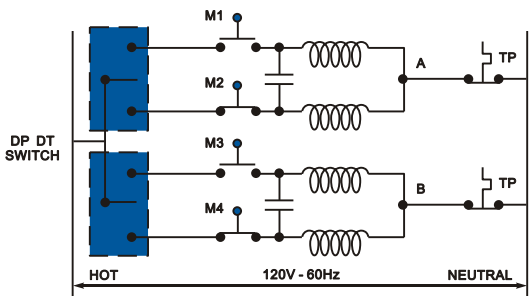

CORRECT

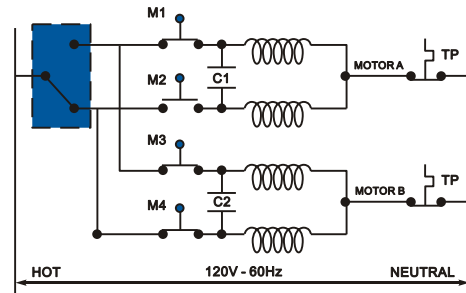

INCORRECT

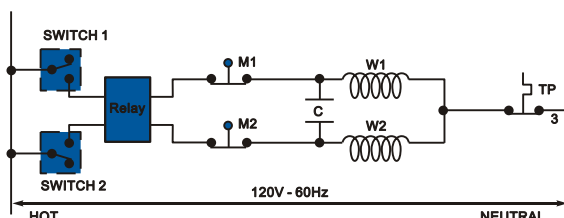

CORRECT

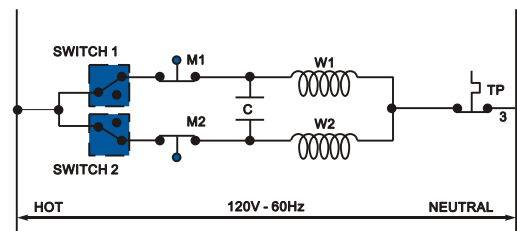

INCORRECT



Wiring Considerations

(Three Wire Operators / Hz Operators)

OPERATOR WIRING CHART

MOTOR CABLE	POWER 120VAC
BLACK	HOT
WHITE	NEUTRAL
GREEN	GROUND

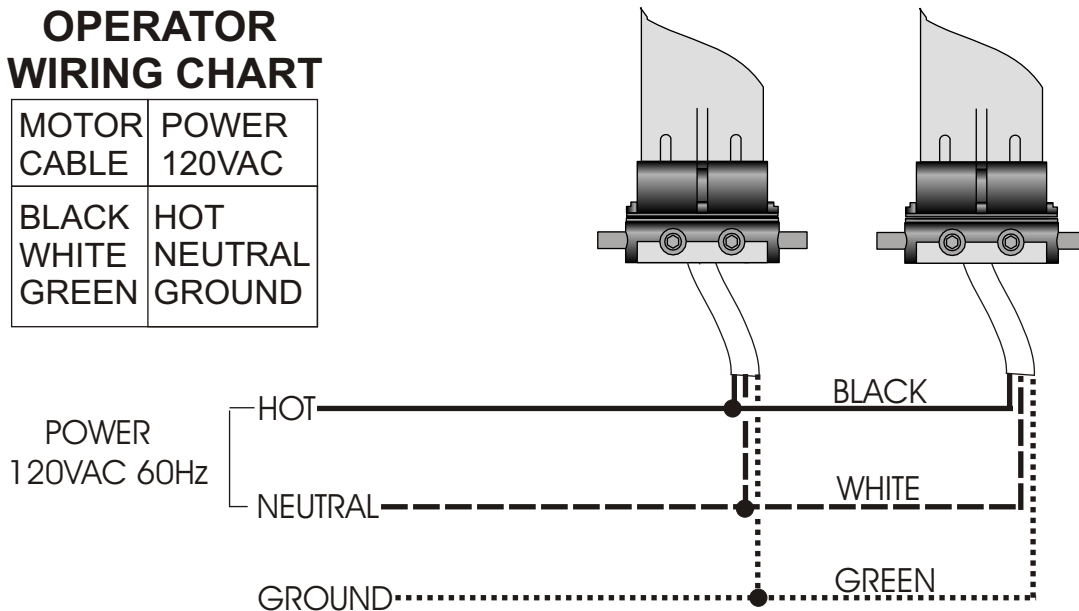

1) FCC

- This device complies with part 15 of the FCC Rules. Operating is subject to the following two conditions:
(1) This device may not cause harmful interference, and (2) This device must accept any interference received, including interference that may cause undesired operation.
- Caution: Changes or modifications not expressly approved by the party responsible for compliance could void the user's authority to operate the equipment.

2) Hz Operator Wiring

All wiring must conform to the National Electrical Code and local codes

- The Hz operator can be wired to power in parallel (unlike normal AC tubular operators)
- It is recommended that provisions be made to cut power individually when wiring Hz operators.** This can be in the form of an inline off/on switch, a disconnect plug, or access to the operator cable for use of a installers power cable with off/on switch. The ability to cut the power to each motor individually is required to easily program the receiver in the operator.

3) Installation

- The Hz motor uses standard T5 (not DMI) accessories.
- Use only SIMU accessories (brackets, adaptors, clips....)
- Mount Hz motor heads **at least** 18 inches from each other to prevent RF interference.
- Always install the power cable with a drip loop to prevent water penetration
- SIMU motors conform to IP44 requirements and as such must be protected against direct weather elements such as rain, sleet, ...etc.



Hz-02 Plus Operators (Electronic Limit) Basic Programming

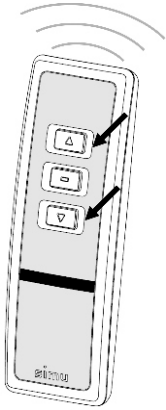

STEP 1

Wake the motor by pressing the **UP** and **DOWN** buttons simultaneously until the motor jogs

Note: After every command the motor will jog to confirm

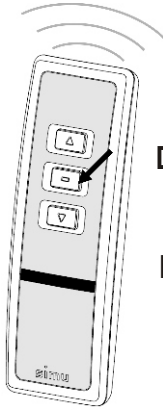

STEP 2

Check the direction of rotation with the **UP** or **DOWN** button. If needed, change the direction of rotation by pressing and holding the **STOP** button until the motor jogs.

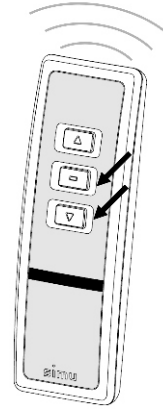

STEP 3

Run the motor to the desired upper limit. Press the **STOP** and **DOWN** buttons simultaneously until the motor starts to run downward. Use the **STOP** button to stop the motor near the desired lower limit.

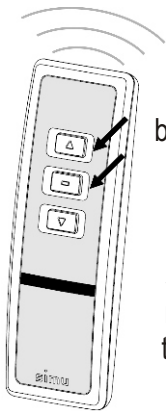

STEP 4

Use the **UP** or **DOWN** button to run the motor to the exact desired lower limit. Press the **STOP** and **UP** buttons simultaneously until the motor starts to run. Use the **STOP** button to stop the motor.

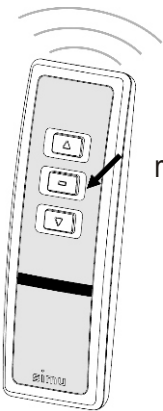

STEP 5

Press and hold the **STOP** button until the motor jogs to confirm the limit settings.
Note: Until this step, the up or down limit can be moved by repeating step 3 or step 4

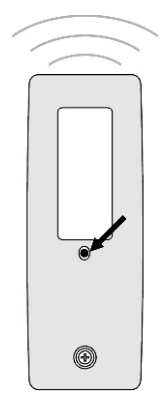

STEP 6

Press and hold the **PROGRAM** button on the back of the transmitter until the motor jogs. The buttons no longer have to be held for the motor to run. Double check the limits are in the desired position

IMPORTANT: The programming button in step 6 will not work until the limits have been confirmed as per step 5

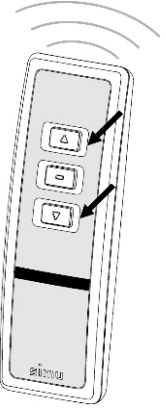

ADJUSTING THE LIMITS AFTER THE MOTOR HAS BEEN PROGRAMMED.

To change the upper limit run the motor to its upper limit and let it stop. Press the **UP** and **DOWN** buttons simultaneously until the motor jogs. Run the motor to the new desired upper limit. Press and hold the **STOP** button until the motor jogs. Check the new limit.

To change the lower limit run the motor to its lower limit and let it stop. Press the **UP** and **DOWN** buttons simultaneously until the motor jogs. Run the motor to the new desired lower limit. Press and hold the **STOP** button until the motor jogs. Check the new limit.

To add or delete a remote/channel press the **PROGRAMMING** button on the back of an already programmed remote/channel until the motor jogs. Next press the **PROGRAMMING** button on the back of the remote/channel you wish to add or delete until the motor jogs.

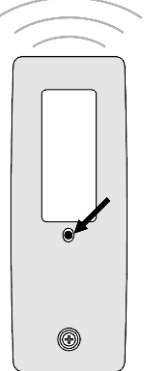

To reset the motor to factory mode start with the motor connected to power. Cut power for 8 seconds, reconnect power for 8 seconds, cut power for 8 seconds and then reconnect power. The motor should start to run (if this does not happen repeat the 8 second power cuts until the motor does run). Allow the motor to stop on its own (do not press stop, up or down or you will have to repeat the double power cut) Once the motor stops on its own, press and **hold** the **PROGRAMMING** button for over 8 seconds. The motor should jog twice.



Hz-02 (Progressive Limit) Basic Programming

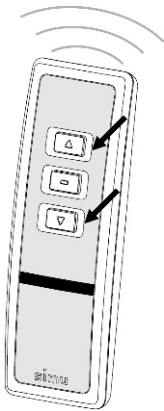

STEP 1

Wake the motor by pressing the **UP** and **DOWN** buttons simultaneously until the motor jogs.

Note: After every command the motor will jog to confirm

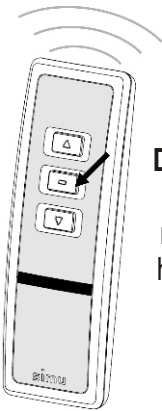

STEP 2

Check the direction of rotation with the **UP** or **DOWN** button. If needed, change the direction of rotation by pressing and holding the **STOP** button until the motor jogs.

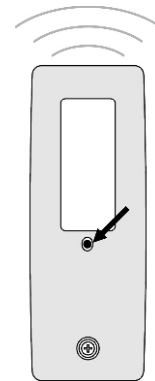

STEP 3

Press and hold the **PROGRAM** button on the back of the transmitter until the motor jogs. The buttons no longer have to be held for the motor to run. Double check the limits are in the desired position.

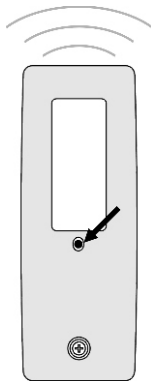

To add or delete a remote/channel press the **PROGRAMMING** button on the back of an already programmed remote until the motor jogs. Next press the **PROGRAMMING** button on the back of the remote you wish to add or delete until the motor jogs.

To reset the motor to factory mode start with the motor connected to power. Cut power for 8 seconds, reconnect power for 8 seconds, cut power for 8 seconds and then reconnect power. The motor should start to run (if this does not happen repeat the 8 second power cuts until the motor does run). Allow the motor to stop on its own (do not press stop, up or down or you will have to repeat the double power cut) Once the motor stops on its own, press and **hold** the **PROGRAMMING** button for over 8 seconds. The motor may jog twice.

Wall Switch Transmitter

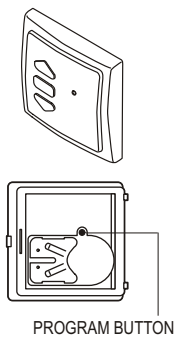

Decorator Wall switch

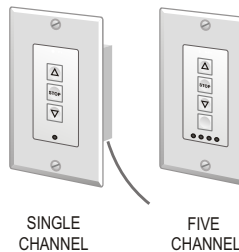

Side of Transmitter

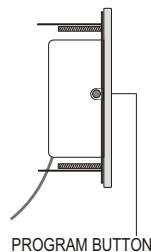

Handheld Transmitter

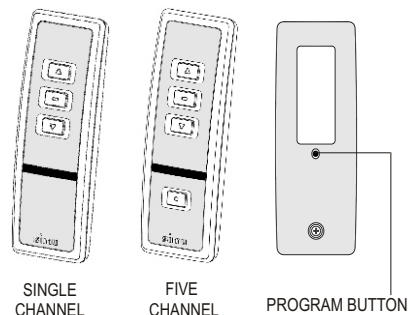

Hz Timer

